

Owner's Manual & Safety Instructions

Save This Manual Keep this manual for the safety warnings and precautions, assembly, operating, inspection, maintenance and cleaning procedures. Write the product's serial number in the back of the manual near the assembly diagram (or month and year of purchase if product has no number). Keep this manual and the receipt in a safe and dry place for future reference.

23g

PORTLAND™

42cc | 2-STROKE

18" GAS CHAINSAW



⚠ DANGER

Using an engine indoors
CAN KILL YOU IN MINUTES.

Engine exhaust contains carbon monoxide.
This is a poison you cannot see or smell.



NEVER use inside
a home or garage,
EVEN IF doors and
windows are open.



Only use **OUTSIDE**
and far away from
windows, doors,
and vents.

57436

Visit our website at: <http://www.harborfreight.com>
Email our technical support at: productsupport@harborfreight.com

When unpacking, make sure that the product is intact and undamaged. If any parts are missing or broken, please call 1-888-866-5797 as soon as possible.

⚠ WARNING

Read this material before using this product.
Failure to do so can result in serious injury.
SAVE THIS MANUAL.

Copyright© 2023 by Harbor Freight Tools®. All rights reserved.
No portion of this manual or any artwork contained herein may be reproduced in any shape or form without the express written consent of Harbor Freight Tools. Diagrams within this manual may not be drawn proportionally. Due to continuing improvements, actual product may differ slightly from the product described herein. Tools required for assembly and service may not be included.

Table of Contents

Specifications	2	Maintenance	19
Safety	4	Troubleshooting	24
Setup	8	Parts List and Diagram	26
Operation	12	Warranties	30

Specifications







Engine	Displacement		42cc (41.9 cm ³)	
	Engine Type		Single Cylinder 2-stroke	
	Max Engine Power		1.7 kW	
	Cooling System		Forced air cooled	
	Fuel	Type	87+ octane stabilizer-treated unleaded gasoline containing no more than 10% ethanol (E10) mixed with 2-Stroke oil (see below)	
		Capacity	9.5 fl. oz.	
	Oil	Type	2-Stroke oil must meet either JASO M345 FD or ISO-L-EGD requirements for air-cooled engines, synthetic	
		Ratio	50:1 gasoline-to-oil ratio 2.6 oz oil per gallon of gasoline	
	Bore x Stroke		41.5mm x 31 mm	
	Compression Ratio		11:1	
	Spark Plug	Type	Champion® RCJ7Y / Torch® L7RTC Bosch® L8RTF / NGK® BPMR7A DENSO® W22MPR	
		Gap	0.02"	
	Speed	Idle	3000±400 RPM	
Maximum		1200/min		
Chainsaw	Saw Chain	Length	18"	
		Pitch	0.375"	
		Gauge	0.050"	
		Model	Oregon 91P062X	
	Guide Bar	Length	18"	
		Model	Oregon 180SDEA041	
	Lubrication	Type	Bar and chain oil	
Capacity		7.8 fl. oz.		







The emissions control system for this Engine is warranted for standards set by the U.S. Environmental Protection Agency. For warranty information, refer to the last pages of this manual.

WARNING SYMBOLS AND DEFINITIONS

	This is the safety alert symbol. It is used to alert you to potential personal injury hazards. Obey all safety messages that follow this symbol to avoid possible injury or death.
⚠ DANGER	Indicates a hazardous situation which, if not avoided, will result in death or serious injury.
⚠ WARNING	Indicates a hazardous situation which, if not avoided, could result in death or serious injury.
⚠ CAUTION	Indicates a hazardous situation which, if not avoided, could result in minor or moderate injury.
NOTICE CAUTION	Addresses practices not related to personal injury.

Symbol Definitions

Symbol	Property or Statement
RPM	Revolutions Per Minute
HP	Horsepower
	WARNING marking concerning Risk of Eye Injury. Wear ANSI-approved safety goggles with side shields.
	Read the manual before set-up and/or use.
	WARNING marking concerning Risk of Hearing Loss. Wear hearing protection.
	Wear head protection.
	WARNING marking concerning Risk of Respiratory Injury. Operate engine OUTSIDE and far away from windows, doors, and vents.
	WARNING marking concerning Risk of Fire while handling fuel. Do not smoke while handling fuel.

Symbol	Property or Statement
	WARNING marking concerning Risk of Fire. Do not refuel while operating. Keep flammable objects away from engine.
	WARNING marking concerning Risk of Kickback. Contact of the guide bar tip with any object should be avoided.
	WARNING marking concerning Risk of Kickback. Tip contact can cause the guide bar to move suddenly upward and backward, which can cause serious injury.
	WARNING marking concerning Risk of Loss of Control. Do not operate the chainsaw with only one hand.
	WARNING marking concerning Risk of Loss of Control. Always use two hands when operating the chainsaw.
	WARNING marking concerning Saw Chain Orientation. Cutters must face in direction of rotation.

IMPORTANT SAFETY INSTRUCTIONS



SAVE THESE INSTRUCTIONS –

This manual contains important instructions that should be followed during setup, operation and maintenance of the chainsaw.

Kickback Safety Precautions

WARNING! Kickback may occur when the nose or tip of the guide bar touches an object, or when the wood closes in and pinches the saw chain in the cut. Tip contact in some cases may cause a lightning-fast reverse reaction, kicking the guide bar up and back toward the operator. Pinching the saw chain along the top of the guide bar may push the guide bar rapidly back toward the operator. Either of these reactions may cause you to lose control of the saw, which could result in serious personal injury. Do not rely exclusively upon the safety devices built into your saw. As a chainsaw user, you should take several steps to keep your cutting jobs free from accident or injury.

- a. With a basic understanding of kickback, you can reduce or eliminate the element of surprise. Sudden surprise contributes to accidents.

- b. Keep a good firm grip on the saw with both hands, the right hand on the rear handle and the left hand on the front handle, when the engine is running. Use a firm grip with thumbs and fingers encircling the chain saw handles. A firm grip will help reduce kickback and maintain control of the saw. Don't let go.
- c. Make sure that the area in which you are cutting is free from obstructions. Do not let the nose of the guide bar contact a log, branch, or any other obstruction that could be hit while you are operating the saw.
- d. Cut at high engine speeds.
- e. Do not overreach or cut above shoulder height.
- f. Follow the manufacturer's sharpening and maintenance instructions for the saw chain.
- g. Only use replacement bars and chains specified by the manufacturer or the equivalent.

Other Safety Precautions

- Do not operate a chain saw with one hand! Serious injury to the operator, helpers, bystanders, or any combination of these persons may result from one-handed operation.
- A chain saw is intended for two-handed use.
- Do not operate a chain saw when you are fatigued.
- Use safety footwear; snug-fitting clothing; protective gloves; and eye, hearing, and head protection devices.
- Use caution when handling fuel. Mix and pour fuel outdoors where there are no sparks and flames. Slowly remove the fuel cap only after stopping the engine and allowing the chain saw to cool. Do not smoke while fueling or mixing fuel. Move the chain saw at least 10 feet (3 m) from the fueling point before starting the engine.
- Do not allow other persons to be near the chain saw when starting or cutting with the chain saw. Keep bystanders and animals out of the work area.
- Do not start cutting until you have a clear work area, secure footing, and a planned retreat path from the falling tree.
- Keep all parts of your body away from the saw chain when the engine is running.
- Before you start the engine, make sure that the saw chain is not contacting anything.
- Carry the chain saw with the engine stopped, the guide bar and saw chain to the rear, and the muffler away from your body.
- Do not operate a chain saw that is damaged, improperly adjusted, or not completely and securely assembled. Be sure that the saw chain stops moving when the throttle control trigger is released.
- Shut off the engine before setting the chain saw down.
- Use extreme caution when cutting small-size brush and saplings because slender material may catch the saw chain and be whipped toward you or pull you off balance.
- When cutting a limb that is under tension, be alert for spring back so that you will not be struck when the tension in the wood fibers is released.
- Keep the handles dry, clean, and free of oil or fuel mixture.
- Operate the chain saw only in well-ventilated areas.

- Do not operate a chain saw in a tree unless you have been specifically trained to do so. All chain saw service, other than the items listed in the operator's manual(s) maintenance instructions, should be performed by competent chain saw service personnel. (For example, if improper tools are used to remove the flywheel or if an improper tool is used to hold the flywheel in order to remove the clutch, structural damage to the flywheel could occur and subsequently could cause the flywheel to burst.)

- Allow the chain saw to cool before performing maintenance or adjustments.
- When transporting your chain saw, use the appropriate guide-bar cover.

Set up Precautions

1. Gasoline fuel and fumes are flammable, and potentially explosive. Use proper fuel storage and handling procedures. Do not store fuel or other flammable materials nearby.
2. Have multiple ABC class fire extinguishers nearby.
3. Operation of this equipment may create sparks that can start fires around dry vegetation. A spark arrestor may be required. The operator should contact local fire agencies for laws or regulations relating to fire prevention requirements.
4. Set up and use only on a flat, level, well-ventilated surface.
5. Wear ANSI-approved safety goggles, heavy-duty work gloves, and dust mask/respirator during set up.
6. Use only lubricants and fuel recommended in the Specifications chart of this manual.

Operating Precautions

1.  **CARBON MONOXIDE HAZARD**
Using an engine indoors **CAN KILL YOU IN MINUTES.**
Engine exhaust contains carbon monoxide. This is a poison you cannot see or smell.

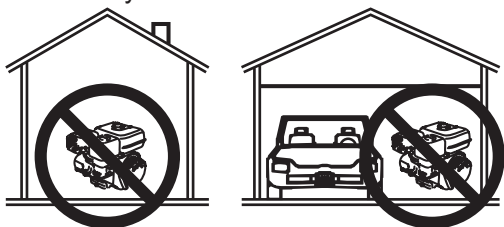

NEVER use inside a home or garage, EVEN IF doors and windows are open.

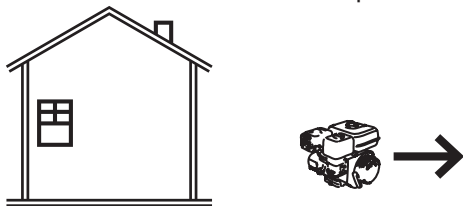

Only use OUTSIDE and far away from windows, doors, and vents.

2. Keep children away from the equipment, especially while it is operating.
3. Fire Hazard! Do not fill fuel tank while engine is running. Do not operate if gasoline has been spilled. Clean spilled gasoline before starting engine. Do not operate near pilot light or open flame.
4. Do not touch engine during use. Let engine cool down after use.
5. Never store fuel or other flammable materials near the engine.
6. Only use a suitable means of transport and lifting devices with sufficient weight bearing capacity when transporting the equipment.
7. Secure the equipment on transport vehicles to prevent it from rolling, slipping, and tilting.
8. Industrial applications must follow OSHA requirements.
9. Do not leave the equipment unattended when it is running. Turn off the equipment (and remove safety keys, if available) before leaving the work area.
10. The equipment can produce high noise levels. Prolonged exposure to noise levels above 85 dBA is hazardous to hearing. Wear ear protection when operating the chain saw or when working nearby while it is operating.
11. People with pacemakers should consult their physician(s) before use. Electromagnetic fields in close proximity to a heart pacemaker could cause pacemaker interference or pacemaker failure. Caution is necessary when near the engine's magneto or recoil starter.
12. Use only accessories that are recommended by Harbor Freight Tools for your model. Accessories that may be suitable for one piece of equipment may become hazardous when used on another piece of equipment.
13. Do not operate in explosive atmospheres, such as in the presence of flammable liquids, gases, or dust. Gasoline-powered engines may ignite the dust or fumes.

14. Stay alert, watch what you are doing and use common sense when operating this piece of equipment. Do not use while tired or under the influence of drugs, alcohol or medication.
15. Do not overreach. Keep proper footing and balance at all times. This enables better control of the equipment in unexpected situations.
16. Dress properly. Do not wear loose clothing or jewelry. Keep hair, clothing and gloves away from moving parts. Loose clothes, jewelry or long hair can be caught in moving parts.
17. Parts, especially exhaust system components, get very hot during use. Stay clear of hot parts.
18. Do not cover the equipment during operation.
19. Keep the equipment, engine, and surrounding area clean at all times.
20. Do not smoke, or allow sparks, flames, or other sources of ignition around the equipment, especially when refuelling.
21. Use the equipment, accessories, etc., in accordance with these instructions and in the manner intended for the particular type of equipment, taking into account the working conditions and the work to be performed. Use of the equipment for operations different from those intended could result in a hazardous situation.
22. Do not operate the equipment with known leaks in the engine's fuel system.
23. When spills of fuel or oil occur, they must be cleaned up immediately. Dispose of fluids and cleaning materials as per any local, state, or federal codes and regulations. Store oil rags in a bottom-ventilated, covered, metal container.
24. Keep hands and feet away from moving parts. Do not reach over or across equipment while operating.
25. Before use, check for misalignment or binding of moving parts, breakage of parts, and any other condition that may affect the equipment's operation. **If damaged, have the equipment serviced before using.** Many accidents are caused by poorly maintained equipment.
26. Use the correct equipment for the application. Do not modify the equipment and do not use the equipment for a purpose for which it is not intended.

Service Precautions

1. **Before service, maintenance, or cleaning:**
 - a. **Turn the engine switch to its "OFF" position.**
 - b. **Allow the engine to completely cool.**
 - c. **Then, remove the spark plug cap from the spark plug.**
 2. Keep all safety guards in place and in proper working order. Safety guards include muffler, air cleaner, mechanical guards, and heat shields, among other guards.
 3. **Do not alter or adjust any part of the equipment or its engine that is sealed by the manufacturer or distributor. Only a qualified service technician may adjust parts that may increase or decrease governed engine speed.**
 4. Wear ANSI-approved safety goggles, heavy-duty work gloves, and dust mask/respirator during service.
 5. Maintain labels and nameplates on the equipment. These carry important information. If unreadable or missing, contact Harbor Freight Tools for a replacement.
 6. Have the equipment serviced by a qualified repair person using only identical replacement parts. This will ensure that the safety of the equipment is maintained. Do not attempt any service or maintenance procedures not explained in this manual or any procedures that you are uncertain about your ability to perform safely or correctly.
 7. Store equipment out of the reach of children.
 8. Follow scheduled engine and equipment maintenance.
- Refueling:**
1. Do not refill the fuel tank while the engine is running or hot.
 2. Do not smoke, or allow sparks, flames, or other sources of ignition around the equipment, especially when refuelling.
 3. **Do not fill fuel tank to the top.** Leave a little room for the fuel to expand as needed. **TO PREVENT FUEL LEAKAGE AND FIRE HAZARD, do not fill fuel above the bottom of the Fuel Tank fill neck.**
 4. Refuel in a well-ventilated area only.
 5. Wipe up any spilled fuel and allow excess to evaporate before starting engine. **To prevent FIRE, do not start the engine while the smell of fuel hangs in the air.**

Chain Saw Safety Warnings

1. **Keep all parts of the body away from the saw chain when the chain saw is operating. Before you start the chain saw, make sure the saw chain is not contacting anything.** *A moment of inattention while operating chain saws may cause entanglement of your clothing or body with the saw chain.*
2. **Always hold the chain saw with your right hand on the rear handle and your left hand on the front handle.** Holding the chain saw with a reversed hand configuration increases the risk of personal injury and should never be done.
3. **Hold the power tool by insulated gripping surfaces only, because the saw chain may contact hidden wiring.** *Saw chains contacting a "live" wire may make exposed metal parts of the power tool "live" and could give the operator an electric shock.*
4. **Wear safety glasses and hearing protection. Further protective equipment for head, hands, legs and feet is recommended.** *Adequate protective clothing will reduce personal injury by flying debris or accidental contact with the saw chain.*
5. **Do not operate a chain saw in a tree.** *Operation of a chain saw while up in a tree may result in personal injury.*
6. **Always keep proper footing and operate the chain saw only when standing on fixed, secure and level surface.** *Slippery or unstable surfaces such as ladders may cause a loss of balance or control of the chain saw.*
7. **When cutting a limb that is under tension be alert for spring back.** *When the tension in the wood fibres is released the spring loaded limb may strike the operator and/or throw the chain saw out of control.*
8. **Use extreme caution when cutting brush and saplings.** *The slender material may catch the saw chain and be whipped toward you or pull you off balance.*
9. **Follow instructions for lubricating, chain tensioning and changing accessories.** *Improperly tensioned or lubricated chain may either break or increase the chance for kickback.*
10. **Cut wood only. Do not use chain saw for purposes not intended.** **For example: do not use chain saw for cutting plastic, masonry or non-wood building materials.** *Use of the chain saw for operations different than intended could result in a hazardous situation.*
11. Do not leave the tool unattended when it is running. Turn off the tool before leaving the work area.
12. Chain saws shall be used in accordance with the operating instructions and safety precautions listed in the operator's manual. It shall be the responsibility of the owner to see that such instructions and precautions are given to every operator who uses the chain saw.
13. This product is not a toy. Keep it out of reach of children.
14. The warnings, precautions, and instructions discussed in this instruction manual cannot cover all possible conditions and situations that may occur. It must be understood by the operator that common sense and caution are factors which cannot be built into this product, but must be supplied by the operator.



SAVE THESE INSTRUCTIONS.

Set Up



Read the **ENTIRE IMPORTANT SAFETY INFORMATION** section at the beginning of this manual including all text under subheadings therein before set up or use of this product.

WARNING

TO PREVENT SERIOUS INJURY:

Operate only with proper spark arrestor installed.



Operation of this equipment may create sparks that can start fires around dry vegetation. A spark arrestor may be required. The operator should contact local fire agencies for laws or regulations relating to fire prevention requirements.

TO PREVENT SERIOUS INJURY FROM ACCIDENTAL STARTING: Make sure that the Engine is switched OFF, wait for the Engine to cool, and unplug the spark plug wire before performing any procedure in this section.

At high altitudes, the engine's carburetor, governor (if so equipped), and any other parts that control the fuel-air ratio will need to be adjusted by a qualified mechanic to allow efficient high-altitude use and to prevent damage to the engine and any other devices used with this product.

Note: For additional information regarding the parts listed in the following pages, refer to *Parts List and Diagram* on page 26.

Safety Device Explanation

1. Hand Guard – A guard that protects your hand on the Front Handle from the Saw Chain.
2. Chain Brake – A mechanical braking device designed to quickly stop the Chainsaw and Chain in the event of kickback. If kickback occurs, this safety feature is activated when the operator's hand strikes the Hand Guard/Chain Brake Lever and pushes it forward, stopping the Chain.
3. Trigger Lockout – A movable stop that prevents the unintentional operation of the Trigger until manually activated.
4. Low-Kickback Saw Chain – A low-kickback saw chain is a chain that has met the kickback performance requirements of ANSI/OPEI 8175.1-2021 when tested according to the provisions specified in ANSI/OPEI 8175.1-2021.
5. Spiked Bumper – The pointed teeth used when felling or bucking to pivot the saw and maintain position while sawing.
6. Guide bar – A part that supports and guides the saw chain. Sprocket nose guide bars with the same effective length, the same number of sprocket nose teeth, the same nose radius, and the same pitch may be considered to have the equivalent kickback energy. Kickback energy of all guide bars may be considered to be less for smaller nose radius sizes.

Components and Controls

SAFETY

SETUP

OPERATION

MAINTENANCE

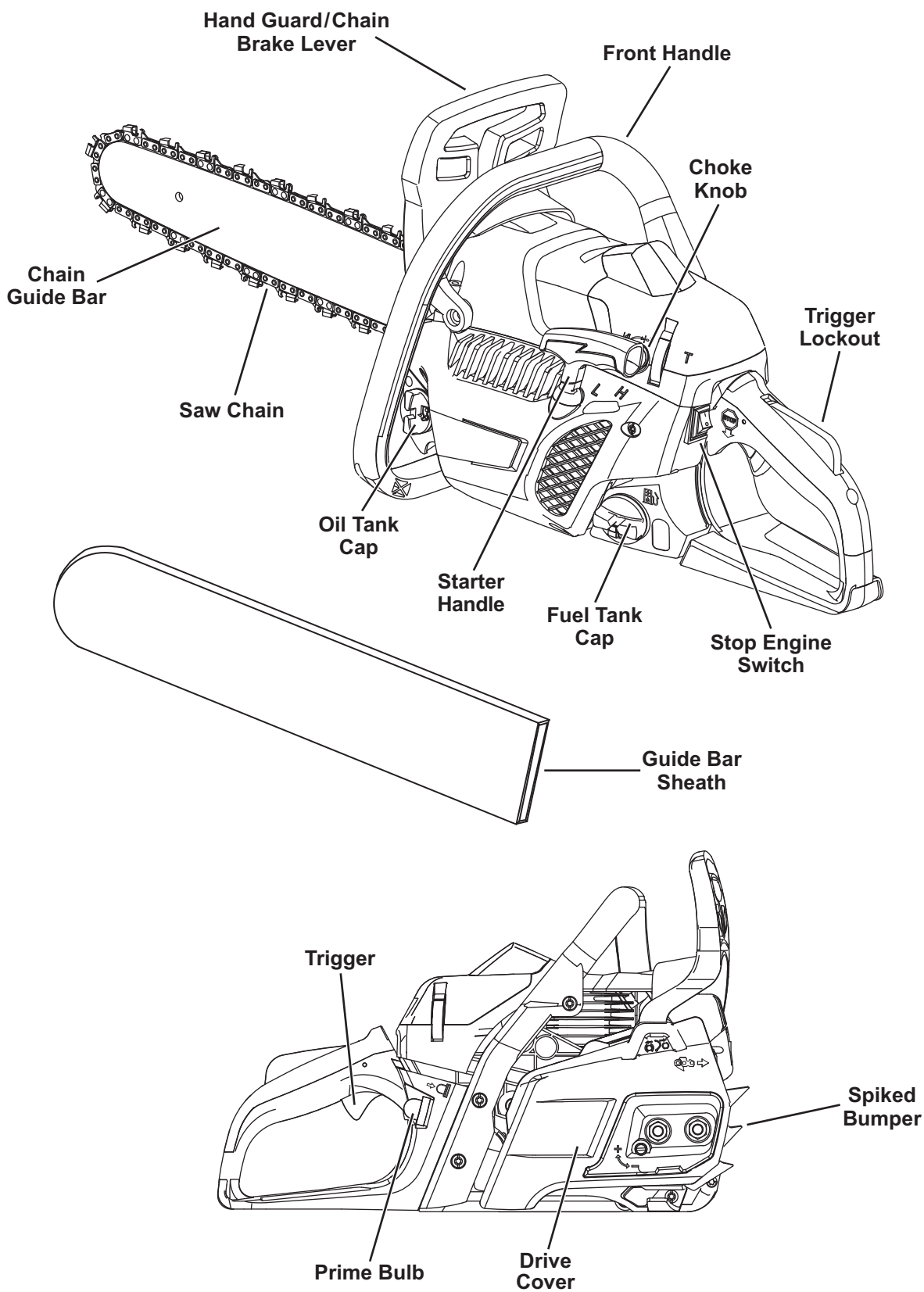

Guide Bar and Saw Chain Installation and Adjustment

SAFETY

SETUP

OPERATION

MAINTENANCE

⚠ WARNING

TO PREVENT SERIOUS INJURY FROM ACCIDENTAL OPERATION:

Make sure that the Engine is switched OFF, wait for the Engine to cool, and unplug the spark plug wire before performing any procedure in this section.

Note: New Saw Chains often need to be tensioned several times during first use. Check a new Saw Chain's tension often when first using.

Follow the directions in the following sections for installing the Guide Bar and Saw Chain, for checking and adjusting Saw Chain tension, and for replacing the Saw Chain when necessary.

Guide Bar/Saw Chain Installation/Replacement

CAUTION! Wear heavy-duty work gloves when handling Saw Chain.

1. **BEFORE FIRST USE:** Soak the Saw Chain overnight in bar and chain oil (sold separately).
2. Pull the Hand Guard/Chain Brake Lever back toward the rear to make sure the chain brake is not on.
3. Loosen and remove the Drive Cover Nuts, then remove the Drive Cover from the Saw.
4. Place the Saw Chain over the Guide Bar. The cutters of the Saw Chain must face away from the Chainsaw along the top edge of the Guide Bar. Fit the Drive Links into the groove around the Guide Bar.
6. Check again that the Saw Chain cutters are aligned properly and the Saw Chain Drive Links are seated completely in the slot of the Guide Bar. The cutters of the Saw Chain must face away from the Chainsaw along the top edge of the Guide Bar.

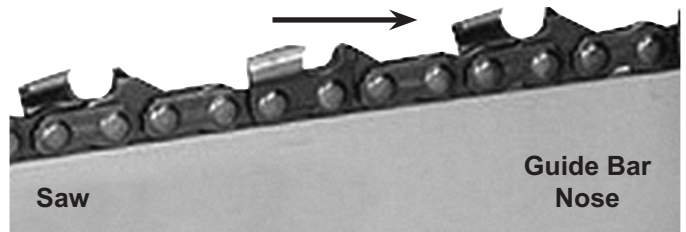
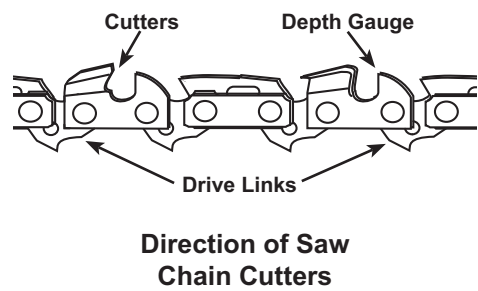
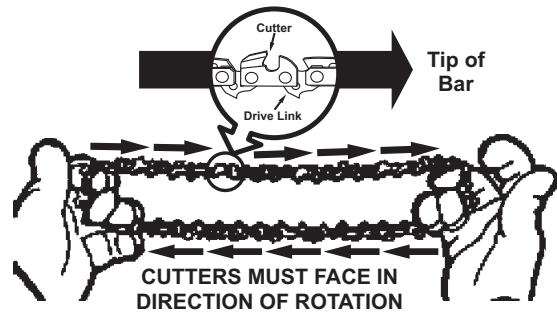
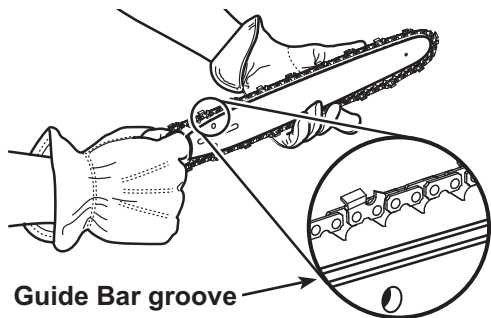

5. Place the slotted end of the Chain Guide Bar over the Guide Bar Bolts and place the Saw Chain over the Drive Sprocket. Refer to Figure A.

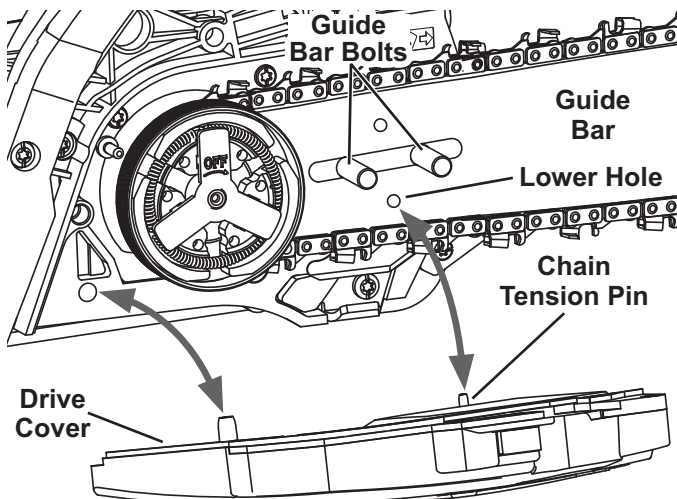

Figure A: Installing Guide Bar and Chain

Figure B: Saw Chain Orientation

7. Replace the Drive Cover, making sure the Chain Tension Pin on the Cover is inserted into the lower hole on the Guide Bar as shown in Figure A. Replace the Drive Cover Nuts and tighten so that the Cover is snug, but not tight. Tension the Saw Chain following the steps in *Checking Saw Chain Tension* and *Adjusting Saw Chain Tension* on page 11.

Checking Saw Chain Tension

1. Before using, check the Saw Chain tension.
2. While wearing heavy-duty gloves, use your index finger and thumb to carefully grab the Saw Chain in the middle section under the Chain Guide Bar.
3. Pull the Saw Chain away from the Guide Bar.
4. The Saw Chain should snap back against the Guide Bar. The Chain should fit snugly in the groove of the Chain Guide Bar, yet you should still be able to slide the chain along the Chain Guide Bar by hand.
5. There should be no sagging between the Guide Bar and Saw Chain on the *underside* of the Guide Bar.

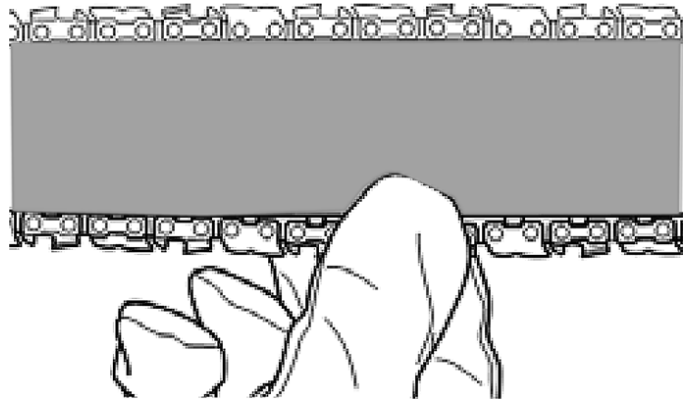

Figure C: Checking Saw Chain Tension

Adjusting Saw Chain Tension

1. Loosen the Drive Cover Nuts on the Drive Cover. It is not necessary to remove the Drive Cover to adjust chain tension.
2. Turn the Chain Tension Screw *clockwise* to increase chain tension and *counterclockwise* to decrease tension.
3. Tighten the Drive Cover Nuts on the Drive Cover while holding the Chain Guide Bar up.
4. Check the Saw Chain tension again following steps 2 through 5 under *Checking Saw Chain Tension* above. If needed, repeat the adjusting steps to achieve the correct tension.

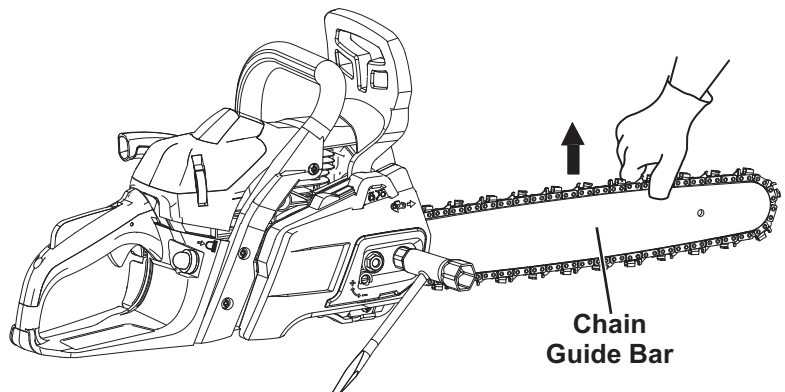
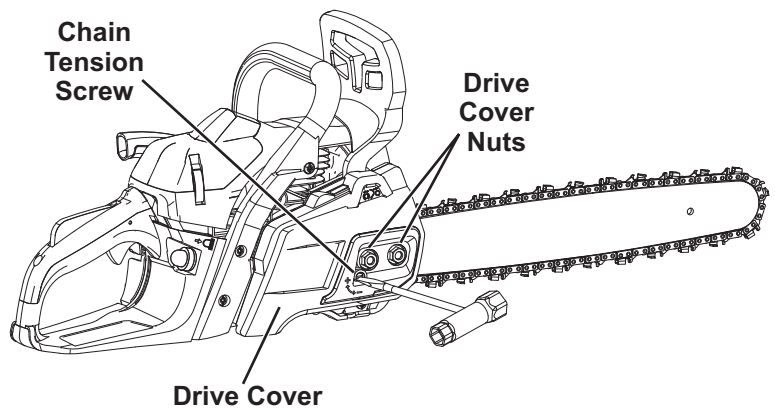

Figure D: Adjusting Saw Chain Tension

Operation



Read the **ENTIRE IMPORTANT SAFETY INFORMATION** section at the beginning of this manual including all text under subheadings therein before set up or use of this product.

Pre-Start Checks

Inspect engine and equipment looking for damaged, loose, and missing parts before set up and starting. If any problems are found, do not use equipment until fixed properly.

Checking and Filling Fuel



WARNING! TO PREVENT SERIOUS INJURY FROM FIRE:

Fill the fuel tank in a well-ventilated area away from ignition sources. If the engine is hot from use, shut the engine off and wait for it to cool before adding fuel. Do not smoke.

1. Clean the Fuel Tank Cap and the area around it.
2. Unscrew and remove the Fuel Tank Cap.

Note: Do not use gasoline containing more than 10% ethanol (E10). Do not use E85 ethanol. Add fuel stabilizer to the gasoline or the Warranty is VOID.

Note: Do not use gasoline that has been stored in a metal fuel container or a dirty fuel container. It can cause particles to enter the carburetor, affecting engine performance and/or causing damage.

IMPORTANT: Your Warranty is VOID if the Engine's Fuel Tank is not filled with the proper mixture (50:1) of **unleaded gasoline and 2-cycle oil** before each use. 2-Stroke oil must meet either JASO M345 FD or ISO-L-EGD requirements for air-cooled engines, synthetic. Before each use, check the fuel level. Do not run the Engine with an improper unleaded gasoline/2-cycle oil mixture. Running the Engine with an improper mixture WILL permanently damage the Engine.

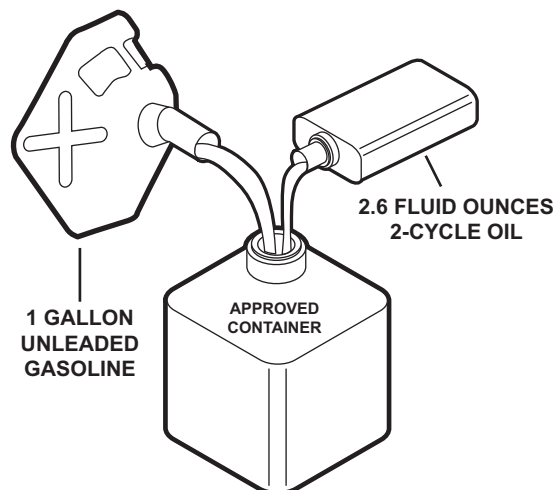

Figure E: Fuel-Oil Mixture

3. To obtain the proper gasoline and 2-cycle oil mixture, mix **2.6 fluid ounces of 2-cycle oil with 1 gallon of unleaded gasoline** into an approved container. Then gently agitate the container to thoroughly mix the gasoline/2-cycle oil.
4. If needed, fill the Fuel Tank to about 1 inch under the fill neck of the Fuel Tank with the pre-mixed unleaded gasoline/2-cycle oil mixture.
5. Then replace the Fuel Tank Cap.
6. Wipe up any spilled fuel and allow excess to evaporate before starting engine. To prevent FIRE, do not start the engine while the smell of fuel hangs in the air.

Starting the Engine

Before Starting the Engine



Before starting the engine:

- a. Inspect the equipment and engine.
- b. Fill the engine with the proper amount and type of unleaded gasoline and 2-cycle oil mixture.
- c. Fill the oil tank with the proper amount and type of bar and chain oil.

Manual Start

A “cold start” is when the engine is no longer hot to the touch, typically at least 30 minutes after it has last been run.

1. To start a cold Engine, ensure the Guide Bar and Saw Chain are not touching or near any object as Chain will spin during startup. Push the Hand Guard/Chain Brake Lever forward to engage the chain brake.

1

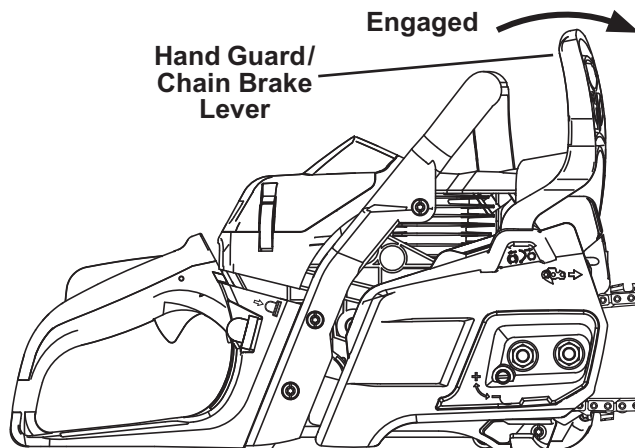

2. Press the Prime Bulb up to 10 times until the Bulb begins to fill with fuel.

2

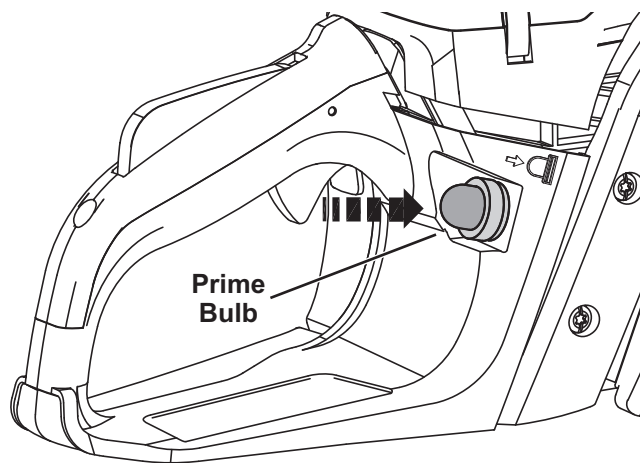

3. Turn the Choke Knob to the START (closed) position.

3

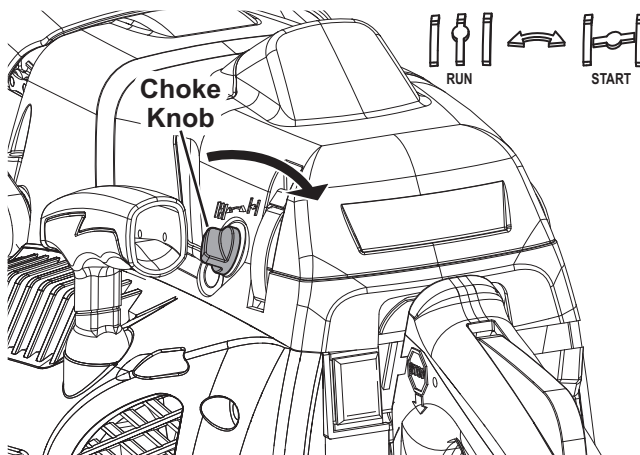

4. Hold the Chain Saw securely on the ground. Firmly grasp the Starter Handle and pull it rapidly until the Engine sputters.

4

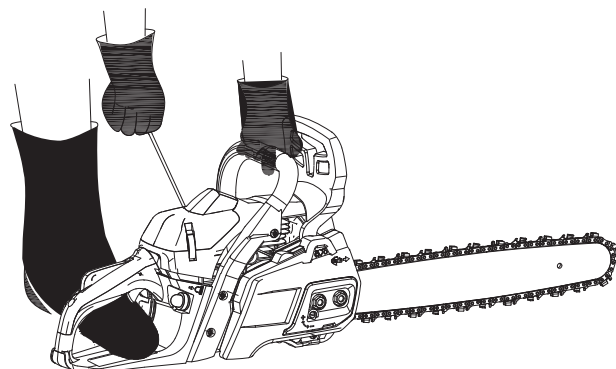

Note: Do not let the Starter Handle snap back against the Engine. Hold it as it recoils so it doesn't hit the Engine.

- Turn the Choke Knob to the RUN (open) position—this will partially engage the throttle to assist starting.

Pull the Starter Handle rapidly until the Engine starts. Immediately disengage the chain brake by pulling back on the Hand Guard/Chain Brake Lever.

Caution! The Saw Chain will immediately start spinning with the Engine running at partial throttle.

Allow the Engine to run at partial throttle for 5 seconds. Quickly squeeze and then release the Trigger to disengage the throttle assist and allow the Engine to idle.

Allow the Engine to warm up at idle for 60 seconds after each start-up so that the Engine can stabilize before use.

5

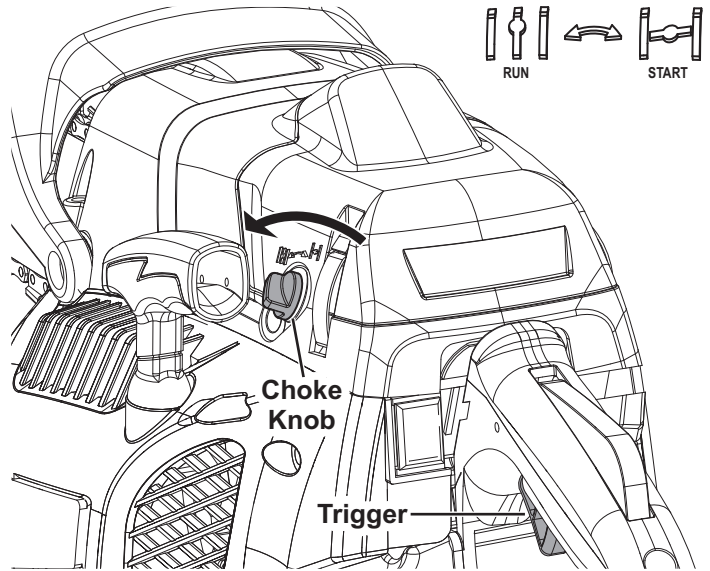

To Restart a Warm Engine

Follow the starting instructions above with the following exception: Omit the portion of Step 4 which states — *Firmly grasp the Starter Handle and pull it rapidly until the Engine sputters* — and proceed to Step 5.

Stopping the Engine

- To stop the engine in an emergency, release the Trigger and press the Stop Engine Switch.
- Under normal conditions, use the following procedure:
 - Release the Trigger.
 - Let Engine idle for 10–30 seconds.
 - Press the Stop Engine Switch.

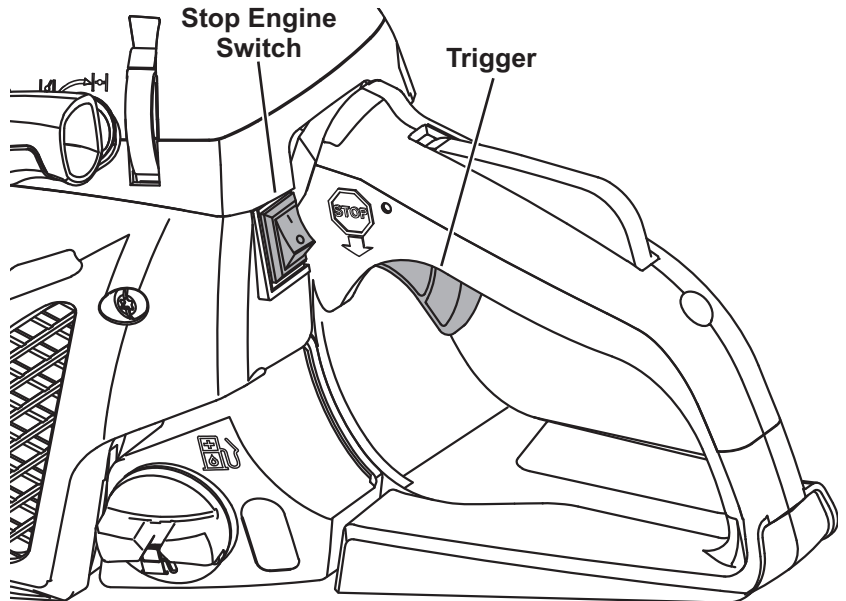

NOTICE

See Long-Term Storage on page 23 for complete storage instructions.

Workpiece and Work Area Set Up

1. Designate a work area that is clean and well lit. The work area must not allow access by children or pets to prevent distraction and injury.
2. There must not be objects, such as utility lines, nearby that will present a hazard while working.
3. A first-time user should, as a minimum practice, cut logs on a saw-horse or cradle before cutting down trees.

General Operating Instructions

1. Before first use and before each use thereafter, remove the Oil Tank Cap. Inspect the Cap Gasket for damage. Fill the Oil Tank to just below fill plug with oil (not included). Refer to *Specifications* chart on page 2 for oil type. Then replace the Oil Tank Cap. Oil is automatically applied to the Saw Chain during operation.
2. Start the Engine as detailed in *Starting the Engine* on page 12. If necessary, adjust Engine idle speed so Saw Chain does not rotate at idle. To adjust, turn the Idle Adjusting Screw (T) counterclockwise to lower idle speed until Chain does not turn. Refer to Figure F.

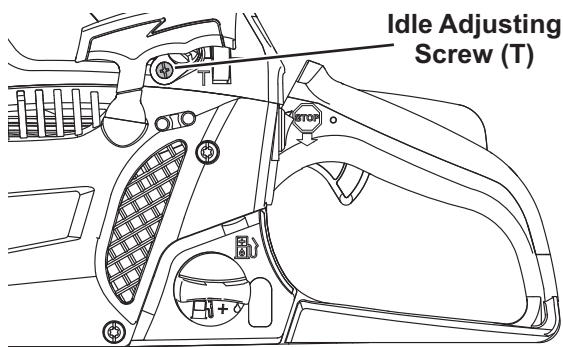

Figure F: Idle Adjusting Screw

3. Place the Hand Guard/Chain Brake Lever in normal operating (disengaged) position by pulling the Hand Guard back toward the Handle. Refer to Figure G.

Note: The Chainsaw will not operate unless the Hand Guard/Chain Brake Lever is in the disengaged position.

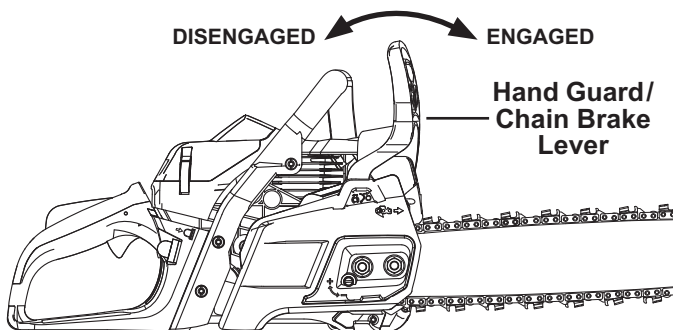

Figure G: Hand Guard/Chain Brake Lever

4. Grasp the Handles with both hands. Always grip the handle with the thumb and fingers encircling the handle as shown in Figure H.
5. Stand in front of the wood to be cut with your feet firmly in place.
6. Grasp the Rear Handle to activate the Trigger Lockout Switch, then squeeze and hold the Trigger. Releasing the Trigger will return the Engine to idling speed.
7. When the Chainsaw reaches full speed, begin cutting with a light, downward pressure against the bottom mid-section of the Saw Chain. Allow the Saw Chain to cut at its own rate. Applying too much pressure can damage the tool.
8. When cutting is complete release the Trigger, allow the Engine to idle for 10–30 seconds, then press the Stop Engine Switch. To prevent accidents, place the Hand Guard/Chain Brake Lever forward in its engaged position after use.
9. When the Saw has cooled completely, clean thoroughly and cover the Chain Guide Bar with the Chain Guide Bar Sheath. Store the tool indoors out of children's reach. See *Long-Term Storage* on page 23 for complete storage instructions.

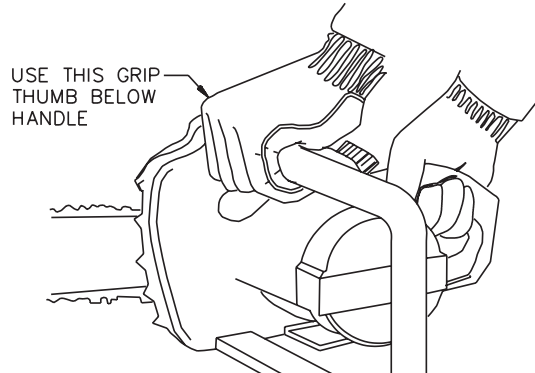

Figure H: Holding the Chainsaw

Note: Front Hand Guard not shown.

- DANGER!** To prevent serious injury and death from kickback: Do not touch the Guide Bar Nose to the wood.
- DANGER!** To prevent serious injury and death from kickback: When cutting loose, round wood stock, place the wood stock on a sawhorse, in a cradle, or use a timberjack (all sold separately) to avoid grabbing and throw back.

Instructions concerning the proper techniques for basic felling, limbing, and cross-cutting

SAFETY

Felling a Tree

When bucking and felling operations are being performed by two or more persons at the same time, the felling operations should be separated from the bucking operation by a distance of at least twice the height of the tree being felled. Trees should not be felled in a manner that would endanger any person, strike any utility line or cause any property damage. If the tree does make contact with any utility line, the company should be notified immediately.

The chainsaw operator should keep on the uphill side of the terrain as the tree is likely to roll or slide downhill after it is felled.

An escape path should be planned and cleared as necessary before cuts are started. The escape path should extend back and diagonally to the rear of the expected line of fall as illustrated in Figure I.

Before felling is started, consider the natural lean of the tree, the location of larger branches and the wind direction to judge which way the tree will fall.

Remove dirt, stones, loose bark, nails, staples and wire from the tree.

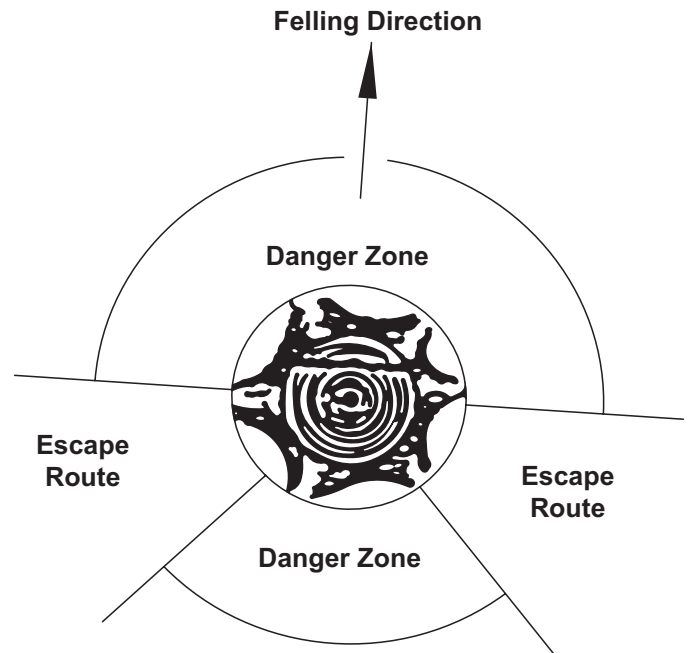

Figure I: Escape Routes

SETUP

Notching Undercut

Make the notch 1/3 the diameter of the tree, perpendicular to the direction of falls as illustrated in Figure J. Make the lower horizontal notching cut first. This will help to avoid pinching either the saw chain or the guide bar when the second notch is being made.

OPERATION

Felling Back Cut

Make the felling back cut at least 2 inches higher than the horizontal notching cut as illustrated in Figure J. Keep the felling back cut parallel to the horizontal notching cut. Make the felling back cut so enough wood is left to act as a hinge. The hinge wood keeps the tree from twisting and falling in the wrong direction. Do not cut through the hinge.

As the felling gets close to the hinge, the tree should begin to fall. If there is any chance that the tree may not fall in desired direction or it may rock back and bind the saw chain, stop cutting before the felling back cut is complete and use wedges of wood, plastic or aluminium to open the cut and drop the tree along the desired line of fall.

When the tree begins to fall remove the chainsaw from the cut, stop the motor, put the chainsaw down, then use the retreat path planned. Be alert for overhead limbs falling and watch your footing.

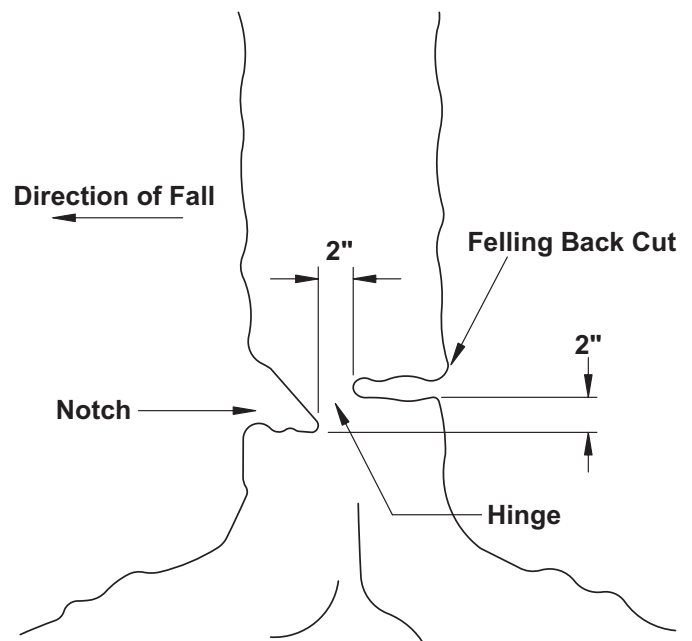
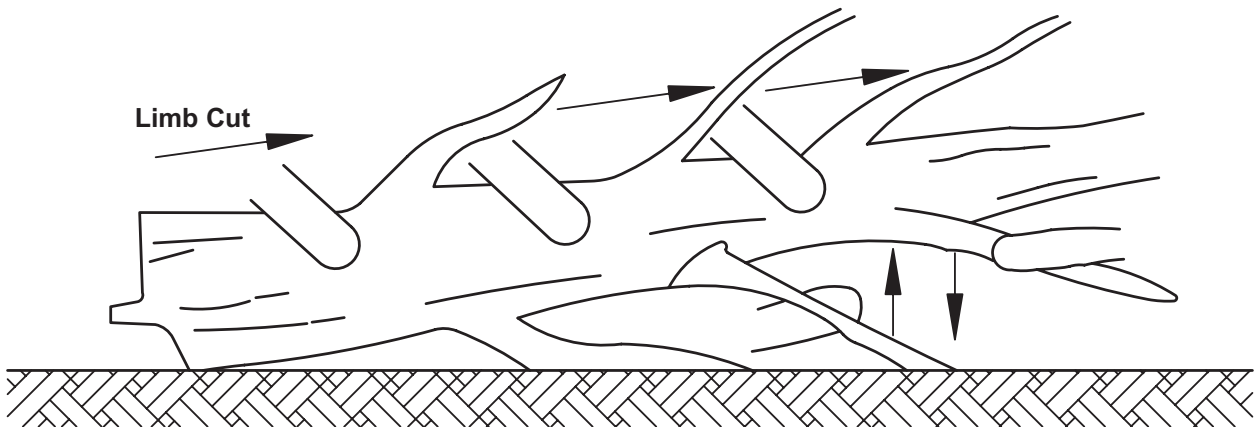

Figure J: Undercutting

MAINTENANCE

Limbing a Tree

Limbing is removing the branches from a fallen tree. When limbing leave larger lower limbs to support the log off the ground. Remove the small limbs in one cut as illustrated in Figure K. Branches under tension should be cut from the bottom up to avoid binding the chainsaw.



Keep work off ground leave support limbs until log is cut

Figure K: Tree Limbing

Bucking a Log

Bucking is cutting a log into lengths. It is important to make sure your footing is firm and your weight is evenly distributed on both feet. When possible, the log should be raised and supported by the use of limbs, logs or chocks. Follow the simple directions for easy cutting.

When the log is supported along its entire length as illustrated in Figure L, it is cut from the top (overbuck).

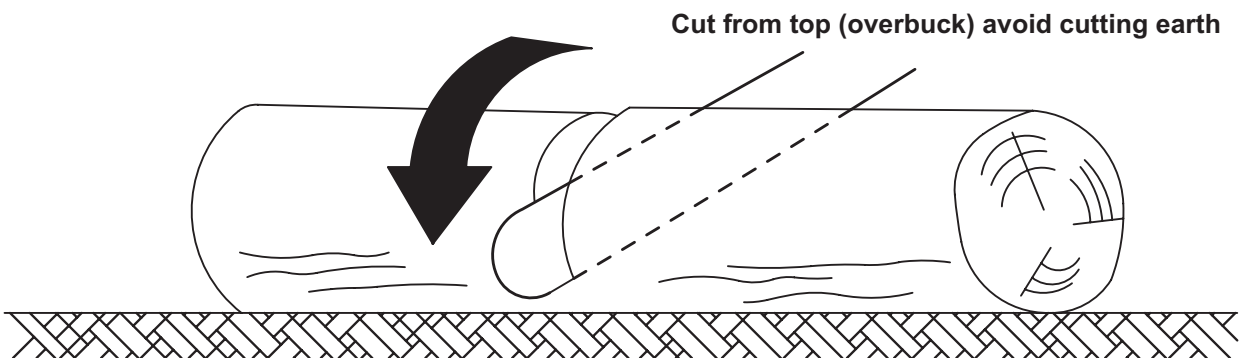

Figure L: Log Supported Along the Entire Length

When the log is supported on one end, as illustrated in Figure M, cut 1/3 the diameter from the underside (underbuck). Then make the finished cut by overbucking to meet the first cut.

2nd cut overbuck (2/3 diameter)
to meet 1st cut (to avoid pinching)

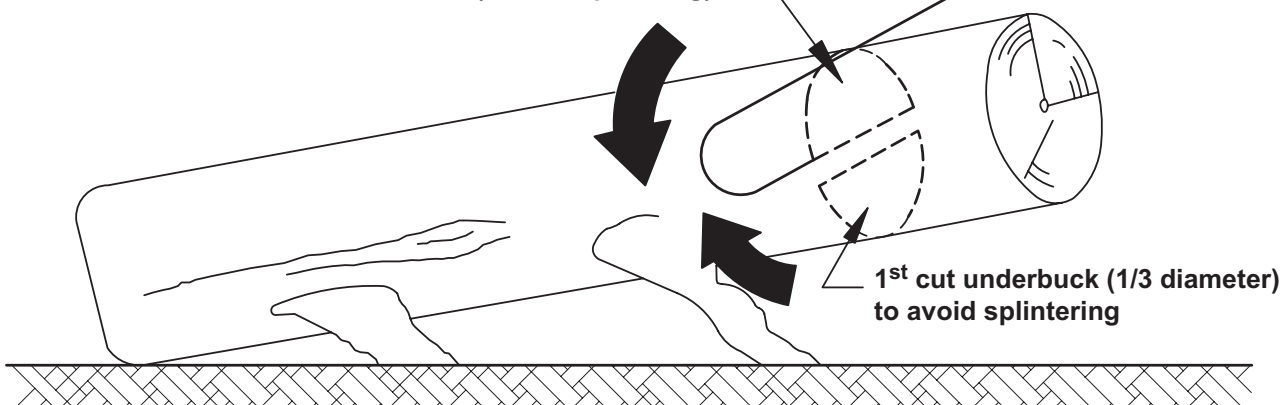

Figure M: Log Supported One End

Bucking a Log (continued)

When the log is supported on both ends, as illustrated in Figure N, cut 1/3 the diameter from the top (overbuck). Then make the finished cut by underbucking the lower 2/3 to meet the first cut.

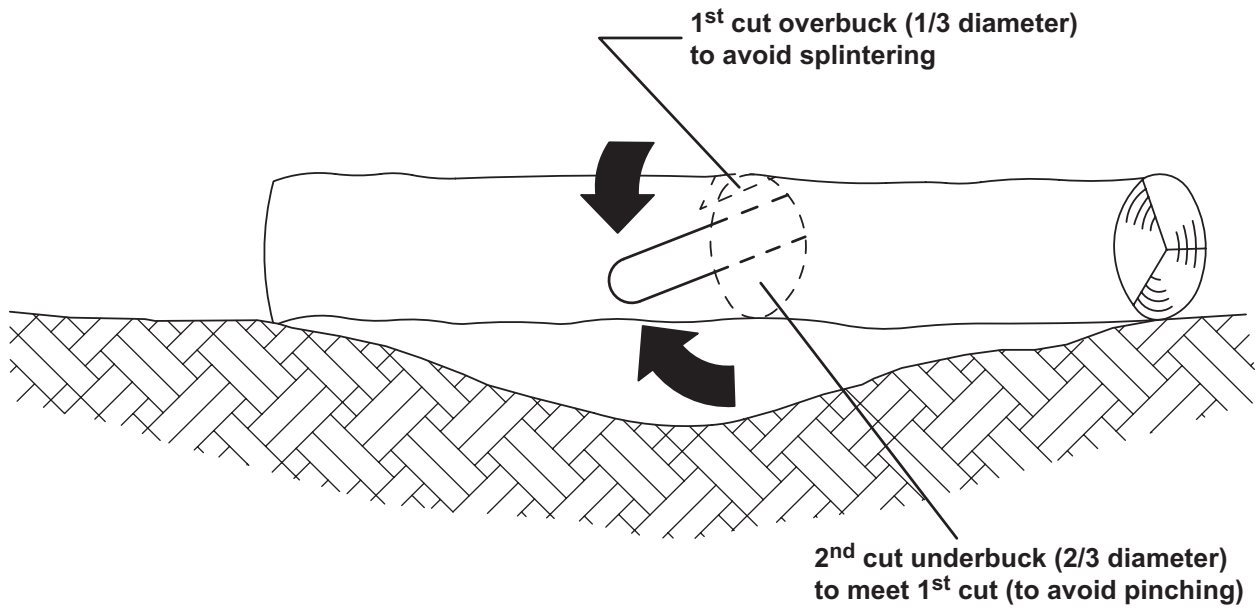
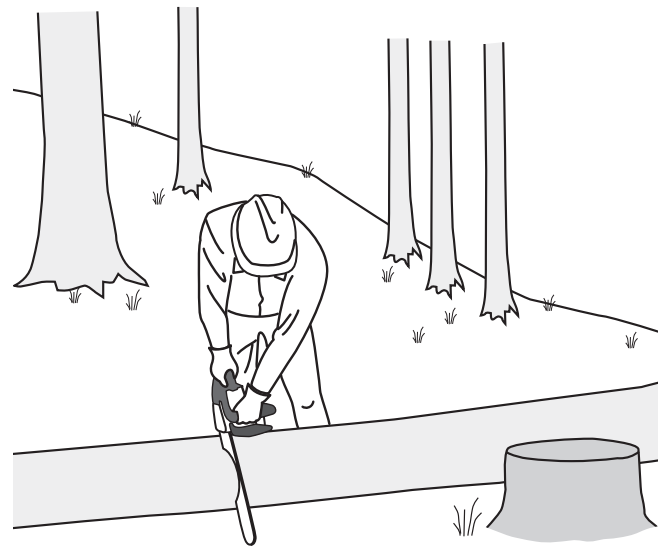

Figure N: Log Supported Both Ends

When bucking on a slope always stand on the uphill side of the log, as illustrated in Figure O. When “cutting through”, to maintain complete control release the cutting pressure near the end of the cut without relaxing your grip on the chainsaw handles. Don’t let the chain contact the ground. After completing the cut, wait for the saw chain to stop before you move the chainsaw. Always stop the motor before moving from tree to tree.



Stand on uphill side when cutting because log may roll

Figure O: Bucking a Log

SAFETY

SETUP

OPERATION

MAINTENANCE

⚠ WARNING**TO PREVENT SERIOUS INJURY FROM ACCIDENTAL STARTING:**

Turn the Power Switch of the equipment to its “OFF” position, wait for the engine to cool, and disconnect the spark plug cap before performing any inspection, maintenance, or cleaning procedures.

TO PREVENT SERIOUS INJURY FROM EQUIPMENT FAILURE:

Do not use damaged equipment. If abnormal noise, vibration, or excess smoking occurs, have the problem corrected before further use.

Follow all service instructions in this manual. The engine may fail critically if not serviced properly.



Many maintenance procedures, including any not detailed in this manual, will need to be performed by a qualified technician for safety. If you have any doubts about your ability to safely service the equipment or engine, have a qualified technician service the equipment instead.

Cleaning, Maintenance, and Lubrication

1. **BEFORE EACH USE**, inspect the general condition of the tool. Check for:
 - loose hardware
 - misalignment or binding of moving parts
 - cracked or broken parts
 - dull or damaged saw chain
 - any other condition that may affect its safe operation.
2. **BEFORE FIRST USE AND BEFORE EACH USE THEREAFTER**, make sure the Oil Tank is filled with oil (not included). Refer to *Specifications Chart* on page 2 for oil type.
3. **IF THE SAW CHAIN BECOMES LOOSE**, adjust the Saw Chain tension as described under *Adjusting Saw Chain Tension* on page 11.
4. **PERIODICALLY OR WHEN REPLACING SAW CHAIN**, turn the Chain Guide Bar over to distribute the wear on it. Replace the Guide Bar when bent, cracked, or when the Saw Chain moves excessively from side to side on the Guide Bar due to wear. Refer to *Chain Guide Bar Care* on page 21.

WARNING! TO PREVENT SERIOUS INJURY: Replace the Saw Chain and Guide Bar only with an identical Saw Chain and Guide Bar.
5. **AFTER USE**, when the Saw has cooled completely, clean thoroughly and cover the Chain Guide Bar with the Chain Guide Bar Sheath. Do not use solvents. Do not immerse this tool in liquid. Store the tool indoors out of children’s reach. See *Long-Term Storage* on page 23 for complete storage instructions.

Cleaning, Maintenance, and Lubrication Schedule

SAFETY

Note: This maintenance schedule is intended solely as a general guide. If performance decreases or if equipment operates unusually, check systems immediately. The maintenance needs of each piece of equipment will differ depending on factors such as duty cycle, temperature, air quality, fuel quality, and other factors. If you have doubts about your ability to safely service this tool, have a qualified technician service the equipment instead.

Note: The following procedures are in addition to the regular checks and maintenance explained as part of the regular operation of the engine and equipment.

Procedure	Before Each Use	Monthly or every 10 hr. of use	Every 3 mo. or 20 hr. of use	Every 6 mo. or 50 hr. of use	Yearly or every 100 hr. of use	Every 2 Years
Brush off outside of engine	✓	✓	✓	✓	✓	✓
Check engine fuel/oil mixture level	✓	✓	✓	✓	✓	✓
Check air cleaner			✓	✓	✓	✓
Clean air filter			✓*	✓	✓	✓
Check and clean spark plug				✓	✓	✓
Check/adjust idle speed	✓					
1. Clean fuel tank and carburetor 2. Clean carbon build-up from combustion chamber					✓**	✓**
Replace fuel line if necessary						✓**

*Service more frequently when used in dusty areas.

**These items should be serviced by a qualified technician.

Periodic Maintenance or When Replacing Saw Chain:

- a. Clean and lubricate Chain Guide Bar and turn over.
- b. Deburr Guide Bar as needed.
- c. Check Chain Sprocket for wear or damage.

Monthly Maintenance:

Clean Chain Oil Tank.

If Worn or Damaged:

- a. Replace Chain Guide Bar if it becomes worn, bent or damaged.
- b. Sharpen or replace Saw Chain.

SETUP

OPERATION

MAINTENANCE

Sharpening/Replacing the Saw Chain

CAUTION! Wear heavy-duty work gloves when handling the Saw Chain.

1. For smooth and safe operation, always keep the Saw Chain cutters sharp.
2. Have the cutters sharpened by a qualified technician when you notice any of the following symptoms:
 - a. The sawdust becomes powder-like.
 - b. You can't make the cut without extra force.
 - c. The Chainsaw does not cut straight.
 - d. Vibration increases.
3. A Saw Chain that is damaged or too worn to be restored to a usable condition by sharpening will need to be replaced. Refer to *Guide Bar/Saw Chain Installation/Replacement* on page 10.

WARNING! TO PREVENT SERIOUS INJURY: Replace the Saw Chain only with an identical Saw Chain.

Chain Guide Bar Care

1. Remove the Chain Guide Bar periodically to clean and lubricate.
2. Deburr rails of Guide Bar as needed. Use a flat file to make side edges square.
5. The rails of the Guide Bar groove should always be parallel to each other. Place a ruler along the surface of the Guide Bar and Saw Chain. If there is a gap, the bar is normal.

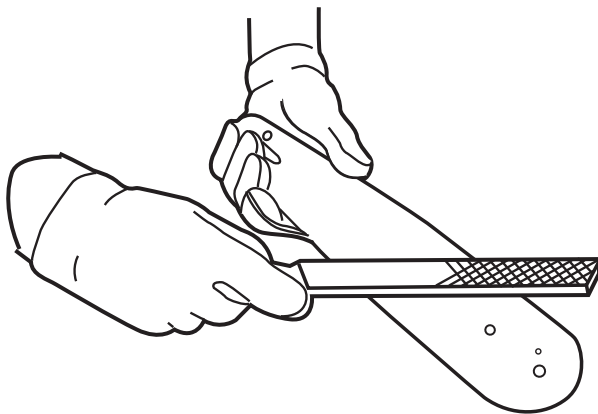

Figure P: Deburring Guide Bar

3. Remove sawdust and sap from the Bar Groove using a Guide Bar cleaning tool (sold separately), then lubricate the nose sprocket at the ports with grease.

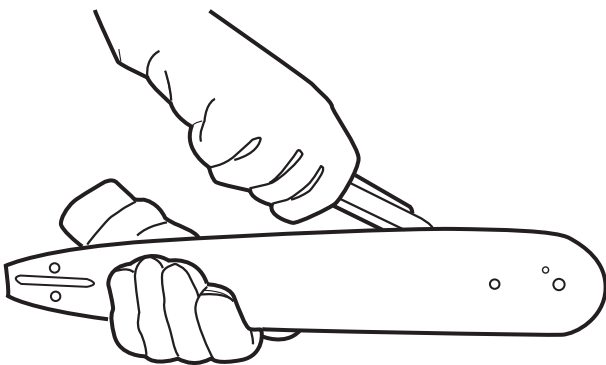

Figure Q: Cleaning and Lubricating Guide Bar

4. Reverse the Guide Bar when replacing the Saw Chain to prevent uneven wear.

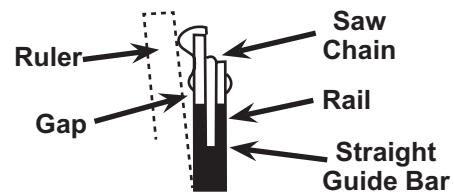

Figure R: Normal Guide Bar

If the ruler is flush with the Guide Bar and Saw Chain, or the Chain tilts to one side, then the Bar is worn and needs to be replaced.

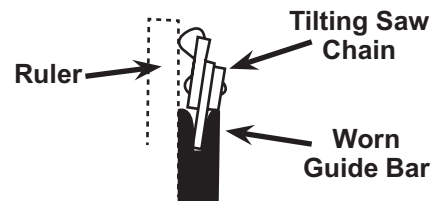

Figure S: Worn Guide Bar

Checking and Filling Fuel



⚠️ WARNING! TO PREVENT SERIOUS INJURY FROM FIRE:

Fill the fuel tank in a well-ventilated area away from ignition sources. If the engine is hot from use, shut the engine off and wait for it to cool before adding fuel. Do not smoke.

1. Clean the Fuel Tank Cap and the area around it.
2. Unscrew and remove the Fuel Tank Cap.

Note: Do not use gasoline containing more than 10% ethanol (E10). Do not use E85 ethanol. Add fuel stabilizer to the gasoline or the Warranty is VOID.

Note: Do not use gasoline that has been stored in a metal fuel container or a dirty fuel container. It can cause particles to enter the carburetor, affecting engine performance and/or causing damage.

IMPORTANT: Your Warranty is VOID if the Engine's Fuel Tank is not filled with the proper mixture (50:1) of unleaded gasoline and 2-cycle oil before each use. 2-Stroke oil must meet either JASO M345 FD or ISO-L-EGD requirements for air-cooled engines, synthetic. Before each use, check the fuel level. Do not run the Engine with an improper unleaded gasoline/2-cycle oil mixture. Running the Engine with an improper mixture WILL permanently damage the Engine.

3. To obtain the proper gasoline and 2-cycle oil mixture, mix **2.6 fluid ounces of 2-cycle oil with 1 gallon of unleaded gasoline** into an approved container. Then gently agitate the container to thoroughly mix the gasoline/2-cycle oil.

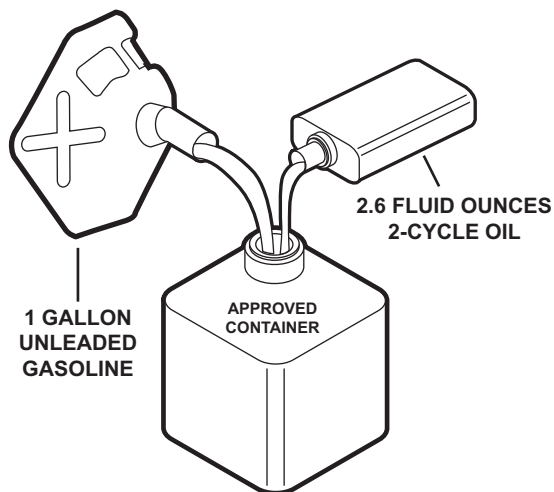
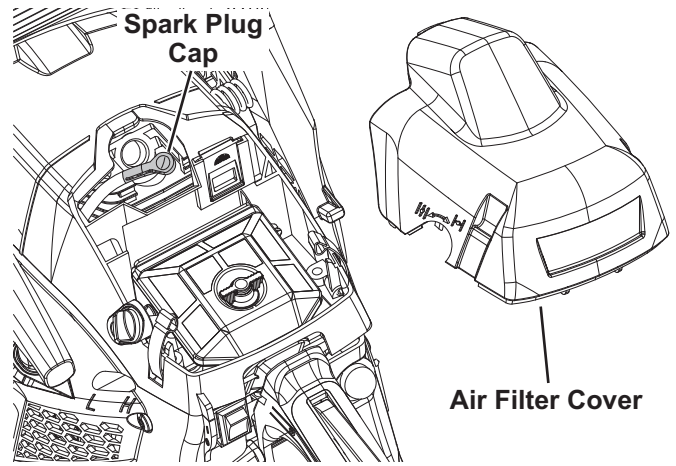

Figure T: Fuel-Oil Mixture

4. If needed, fill the Fuel Tank with the pre-mixed unleaded gasoline/2-cycle oil mixture. Do not fill fuel above the bottom of the Fuel Tank fill neck.
5. Then replace the Fuel Tank Cap.
6. Wipe up any spilled fuel and allow excess to evaporate before starting engine. To prevent FIRE, do not start the engine while the smell of fuel hangs in the air.

Spark plug Maintenance



1. Remove the Air Filter Cover.
2. Disconnect Spark Plug Cap from end of plug. Clean out debris from around Spark Plug.
3. Using a spark plug wrench, remove the Spark Plug.
4. Inspect the Spark Plug:
If the electrode is oily, clean it using a clean, dry rag. If the electrode has deposits on it, polish it using emery paper. If the white insulator is cracked or chipped, the spark plug needs to be replaced.

Recommended Spark Plugs	
Champion®	RCJ7Y
Torch®	L7RTC
Bosch®	L8RTF
NGK®	BPMR7A
DENSO®	W22MPR

NOTICE: Using an incorrect spark plug may damage the engine.

5. When installing a new spark plug, adjust the plug's gap to the specification on the Specifications chart. Do not pry against the electrode, the spark plug can be damaged.
6. Install the new spark plug or the cleaned spark plug into the engine.
 - **Gasket-style:**
Finger-tighten until the gasket contacts the cylinder head, then tighten about 1/2-2/3 turn more.
 - **Non-gasket-style:**
Finger-tighten until the plug contacts the cylinder head, then tighten about 1/16 turn more.

NOTICE: Tighten the Spark Plug properly. **If loose**, the Spark Plug will cause the engine to overheat.

If overtightened, the threads in the engine block will be damaged.

7. Reattach the Spark Plug Cap securely.

Air Filter Maintenance

1. Remove the Air Filter Cover and the Air Filter and check for dirt. Clean or replace as described below.
2. To prevent injury from dust and debris, wear ANSI-approved safety goggles, NIOSH-approved dust mask/respirator, and heavy-duty work gloves. Remove dust on the Filter surface by tapping a corner of the Filter against a hard surface. In a well-ventilated area away from bystanders, use pressurized air to blow dust out of the Filter from the inside.

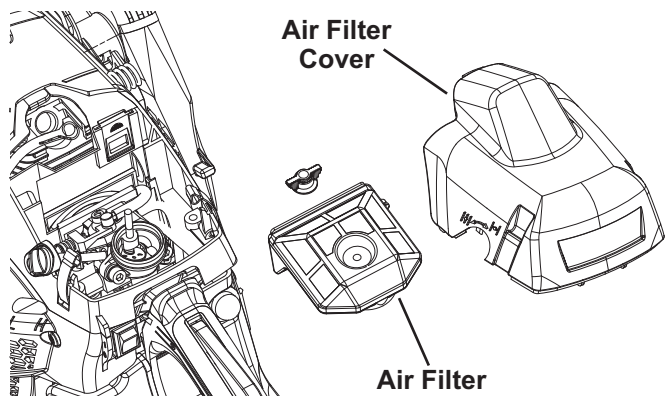

3. Install the new or cleaned filter. Reinstall and secure the Air Filter Cover before use.

Fuel Filter Maintenance

1. Clean the Fuel Tank Cap and the area around it.
2. Remove the Fuel Tank Cap from the Fuel Tank.
3. Use a suction pump (not included) to pump any fuel in the Tank into a proper gasoline container.
4. Use a piece of wire with a hook on one end to carefully extract the Fuel Filter from the Tank.

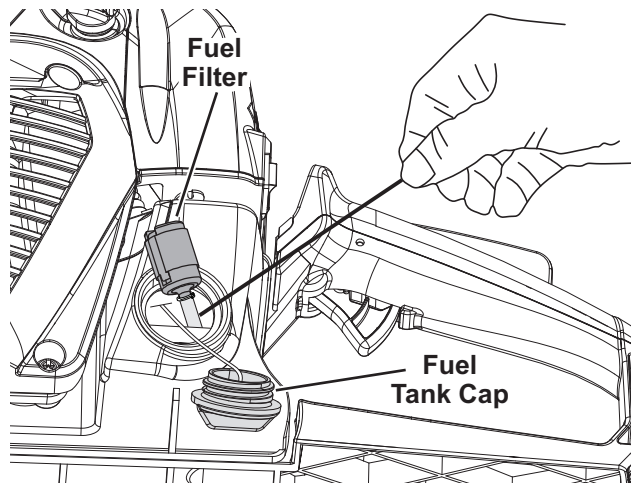

5. Remove used filter from fuel line. Attach a new filter to the fuel line and reinsert into the Fuel Tank.
6. Replace Fuel Tank Cap and tighten securely.

Long-Term Storage

When the equipment is to remain idle for longer than 20 days, prepare the Engine for storage as follows:

1. CLEANING:

Wait for Engine to cool, then clean Engine with dry cloth. **NOTICE: Do not clean using water.** The water will gradually enter the Engine and cause rust damage. Apply a thin coat of rust preventive oil to all metal parts.

2. FUEL:



⚠ WARNING! TO PREVENT SERIOUS INJURY FROM FIRE:

Drain the Fuel Tank in a well-ventilated area away from ignition sources. If the Engine is hot from use, shut the Engine off and wait for it to cool before draining fuel. Do not smoke.

- a. Remove the Fuel Tank Cap and drain any remaining fuel into an approved storage container.
- b. Press the Prime Bulb 10 times.
- c. Drain any residual fuel into the storage container.
- d. Start the Engine and run at idle until the Engine stalls from lack of fuel.
- e. Replace Fuel Tank Cap and tighten securely.

3. LUBRICATION:

- a. Clean out area around spark plug. Remove spark plug and pour 1/2 tablespoon of 2-stroke oil into cylinder through spark plug hole.
- b. Replace spark plug, but leave spark plug cap disconnected.
- c. Pull Starter Handle to distribute oil in cylinder. Stop after one or two revolutions when you feel the piston start the compression stroke (when you start to feel resistance).
- d. Remove all residual bar and chain oil from the Oil Tank.

4. STORAGE AREA:

Cover and store in a dry, level, well-ventilated area out of reach of children. Storage area should also be away from ignition sources, such as water heaters, clothes dryers, and furnaces.

5. AFTER STORAGE:

Before starting the Engine after storage, follow the procedures in *Pre-Start Checks* on page 12. If using pre-mixed fuel that has been stored, keep in mind that during storage some of the gasoline in the fuel evaporates while the 2-stroke oil does not, altering the gasoline-to-oil mix ratio. Running the Engine with an improper mixture WILL permanently damage the Engine. Use freshly mixed fuel when starting the Engine after storage.

Troubleshooting

SAFETY

SETUP

OPERATION

MAINTENANCE

Problem	Possible Causes	Probable Solutions
Engine will not start	FUEL RELATED: <ol style="list-style-type: none"> No fuel in tank. Choke not in START position, cold engine. Gasoline with more than 10% ethanol used. (E15, E20, E85, etc.) Low quality or deteriorated, old gasoline/oil mixture. Carburetor not primed. Dirty fuel passageways. Engine is flooded. Clogged Fuel Filter. 	FUEL RELATED: <ol style="list-style-type: none"> Fill fuel tank with fresh 87+ octane stabilizer-treated unleaded gasoline/oil mixture only. Do not use gasoline with more than 10% ethanol (E15, E20, E85, etc.). Move Choke to START position. Clean out ethanol-rich gasoline from fuel system. Replace components damaged by ethanol. Use fresh 87+ octane stabilizer-treated unleaded gasoline/oil mixture only. Do not use gasoline with more than 10% ethanol (E15, E20, E85, etc.). Use fresh 87+ octane stabilizer-treated unleaded gasoline/oil mixture. Do not use gasoline with more than 10% ethanol (E15, E20, E85, etc.). Press the Prime Bulb several times to prime. Clean out passageways using fuel additive. Heavy deposits may require further cleaning. Remove and clean spark plug. Turn Choke Knob to RUN position and pull Starter Handle 10-20 times to clear excess fuel from cylinder. Replace spark plug and attempt to start with normal process. Clean or replace Fuel Filter.
	IGNITION (SPARK) RELATED: <ol style="list-style-type: none"> Spark plug cap not connected securely. Spark plug electrode wet or dirty. Incorrect spark plug gap. Spark plug cap broken. Incorrect spark timing or faulty ignition system. 	IGNITION (SPARK) RELATED: <ol style="list-style-type: none"> Connect spark plug cap properly. Clean spark plug. Correct spark plug gap. Replace spark plug cap. Have qualified technician diagnose/repair ignition system.
	COMPRESSION RELATED: <ol style="list-style-type: none"> Cylinder not lubricated. Problem after long storage periods. Loose or broken spark plug. (Hissing noise will occur when trying to start.) 	COMPRESSION RELATED: <ol style="list-style-type: none"> Pour 1/2 tablespoon of oil into spark plug hole. Crank engine a few times and try to start again. Tighten spark plug. If that does not work, replace spark plug.
Engine misfires	<ol style="list-style-type: none"> Spark plug cap loose. Incorrect spark plug gap or damaged spark plug. Defective spark plug cap. Old or low quality gasoline/oil mixture. Incorrect compression. 	<ol style="list-style-type: none"> Check cap and wire connections. Re-gap or replace spark plug. Replace spark plug cap. Use only fresh 87+ octane stabilizer-treated unleaded gasoline/oil mixture. Do not use gasoline with more than 10% ethanol (E15, E20, E85, etc.). Diagnose and repair compression. (Use Engine will not start: COMPRESSION RELATED section.)



Follow all safety precautions whenever diagnosing or servicing the equipment or engine.

Problem	Possible Causes	Probable Solutions
Engine stops suddenly	<ol style="list-style-type: none"> 1. Fuel tank empty or full of impure or low quality gasoline/oil mixture. 2. Defective breather valve creating vacuum, preventing proper fuel flow. 3. Faulty magneto. 4. Disconnected or improperly connected spark plug cap. 	<ol style="list-style-type: none"> 1. Fill fuel tank with fresh 87+ octane stabilizer-treated unleaded gasoline/oil mixture. Do not use gasoline with more than 10% ethanol (E15, E20, E85, etc.). 2. Have qualified technician test/replace breather valve. 3. Have qualified technician service magneto. 4. Secure spark plug cap.
Engine stops when under heavy load	<ol style="list-style-type: none"> 1. Dirty air filter 2. Engine running cold. 	<ol style="list-style-type: none"> 1. Clean element. 2. Allow engine to warm up prior to operating equipment.
Engine knocks	<ol style="list-style-type: none"> 1. Old or low quality gasoline/oil mixture. 2. Engine overloaded. 3. Incorrect spark timing, deposit buildup, worn engine, or other mechanical problems. 	<ol style="list-style-type: none"> 1. Fill fuel tank with fresh 87+ octane stabilizer-treated unleaded gasoline/oil mixture. Do not use gasoline with more than 10% ethanol (E15, E20, E85, etc.). 2. Do not exceed equipment's load rating. 3. Have qualified technician diagnose and service engine.
After sudden impact, Engine will run, but equipment will not operate	<ol style="list-style-type: none"> 1. Clutch damaged. 2. Shaft key or other shear pin broken by impact to disconnect engine and limit damage. 	<ol style="list-style-type: none"> 1. Have qualified technician check and replace damaged clutch. 2. Have qualified technician check and replace broken shaft key or other shear pins.
Engine runs, but Chain does not rotate.	<ol style="list-style-type: none"> 1. Chain tension too tight. 2. Guide Bar and/or Chain damaged. 3. Gear train failure. 	<ol style="list-style-type: none"> 1. Adjust Saw Chain tension. 2. Inspect Guide Bar and Chain for damage. Replace Guide Bar and Chain if necessary. 3. Have qualified technician service tool.
Engine runs, Chain rotates but does not cut or cuts poorly.	<ol style="list-style-type: none"> 1. Saw Chain not tensioned properly. 2. Saw Chain dull. 3. Saw Chain installed backwards. 	<ol style="list-style-type: none"> 1. Tension Saw Chain properly. 2. Sharpen Saw Chain or replace. 3. Reverse direction of Saw Chain.
Chain comes off Guide Bar.	<ol style="list-style-type: none"> 1. Chain tension too loose. 2. Guide Bar and Chain not installed correctly. 	<ol style="list-style-type: none"> 1. Adjust Saw Chain tension. 2. Review and correct Guide Bar and Chain installation.
Guide Bar and Chain running hot and smoking.	<ol style="list-style-type: none"> 1. Chain tension too tight. 2. Oil Tank empty. 	<ol style="list-style-type: none"> 1. Adjust Saw Chain tension. 2. Check/refill Oil Tank.



Follow all safety precautions whenever diagnosing or servicing the equipment or engine.

Parts List

SAFETY

SETUP

OPERATION

MAINTENANCE

Part	Description	Qty.
1	Screw M4x20	2
2	Extinction Conductor	1
3	Ignition Coil	1
4	Nut M8x1	1
5	Flywheel	1
6	Semicircular Key	1
7	Rubber Sleeve	1
8	Tapping Screw St4x12	2
9	Screw M5x25	4
10	Oil Seal 12x22x7	1
11	Circuit Board	1
12	Left Crankcase	1
13	Bearing 6201 Grade D	2
14	Crankshaft Assembly	1
15	Piston Pin Clip	2
16	Piston Pin	1
17	Needle Bearing 10x14x12	1
18	Needle Bearing Ring	2
19	Piston	1
20	Piston Ring	2
21	Cylinder Gasket	1
22	Cylinder	1
23	Screw M5x20	4
24	Screw M5x10	1
25	Cover Plate	1
26	Screw M5x20	2
27	Screw M5x20	1
28	Silencer Body	1
29	Support Column	1
30	Silencer Sealing Plate	1
31	Spark Plug	1
32	Plate	2
33	Snap Joint	2
34	Idle Adjusting Guide Set	1
35	Tapping Screw St4x16	1
36	Top Housing	1
37	Hot Blast Valve	1
38	Tapping Screw St4x22	2
39	Air Filter Cover	1
40	Screw	2
41	Front Damper	1
42	Oil Tank Cap	1
43	Oil Tank Cap Seal	1
44	Oil Tank Cap Retainer	1
45	Reset Device	1
46	Spring	1
47	Case Body Sealing Plate	1
48	Pin Φ 5x10	2
49	Right Crankcase	1

Part	Description	Qty.
50	Suction Jet	1
51	Oil Seal 12x22x7	1
52	Tapping Screw St4x12	2
53	Sir Deflector	1
54	Engine Block	1
55	Stop Engine Switch	1
56	Shoe Block	1
57	Chain Retainer	1
58	Tapping Screw St4.8x16	1
59	Screw M5x14	6
60	Oil Tube	1
61	Oil Pump	1
62	Screw M4x12	2
63	Cover Plate	1
64	Turbine Gasket 10x18x1	1
65	Turbine	1
66	Tapping Screw St4x12	2
67	Needle Bearing 10x13x13	1
68	Clutch Shell	1
69	Clutch Adjusting Washer	1
70	Shoe Block	3
71	Clutch Extension Spring	1
72	Retainer	1
73	Bolt M8x42	2
74	Aeration Jet	1
75	Sponge Transition Block	1
76	Damper	1
77	Oil Filter	1
78	Spiked Bumper	1
79	Tapping Screw St4.8x16	2
80	Nozzle	1
81	Oil Filter Screen	1
82	Rubber Sleeve	1
A	Brake Assembly	1
A1	Tapping Screw St4x10	5
A2	Brake Spring Cover Plate	1
A3	Screw M4x8	1
A4	Tensioner Cover Plate	1
A5	Brake Spring	1
A6	Brake Strap	1
A7	Pin 3x9	3
A8	Tapping Screw St4x10	3
A9	Brake Control Rod	1
A10	Pin 3.05x9	3
A11	Secondary Pull-Rod	1
A12	Main Level	1
A13	Clump Weight Level	1
A14	Clump Weight Spring	1
A15	Clump Weight	1

Part	Description	Qty.
A16	Right Cover Assembly	1
A17	Driven Gear	1
A18	Driving Gear	1
A19	Nut M8	2
A20	Nut Plate	1
A21	Tightener Screw	1
A22	Tension Block	1
A23	Flat Washer	2
B	Fuel Tank / Front Handle Assembly	1
B1	Fuel Tank Cap	1
B2	Fuel Tank Cap Seal	1
B3	Fuel Tank Cap Retainer	1
B4	Shock-Reducing Rubber	2
B5	Tapping Screw St5x14	3
B6	Tapping Screw St4x10	1
B7	Plate	1
B8	Fuel Tank Assembly	1
B9	Tapping Screw St4.8x16	1
B10	Damping Spring Socket	3
B11	Damping Spring	3
B12	Tapping Screw St4.8x16	2
B13	Fuel Filter	1
B14	Circlip	1
B15	Tubing Ring	1
B16	Oil Tube 2.5x5x100	1
B17	Oil Tube 2.5x5x200	1
B18	Balancer Body	1
B19	Balancer Seat	1
B20	Prime Bulb	1
B21	Oil Tube 2.5x5x60	
B22	Pin Φ 3x25	1
B23	Limit Block	1
B24	Trigger Torsion Rod Spring	1
B25	Trigger	1
B26	Trigger Control Rack	1
B27	Limited Block	1
B28	Cable Accelerator	1
B29	Handle Cover	1
B30	Tapping Screw St4.8x12	1
B31	Front Handle	1
B32	Tapping Screw St4.8x16	3

Part	Description	Qty.
C	Starter Assembly	1
C1	Label	1
C2	Screw M5x14	1
C3	Start Cover	1
C4	Eyelet	1
C5	Start Rope	1
C6	Start Grip	1
C7	Bossing	1
C8	Drainage Plate	1
C9	Start Coil Spring	1
C10	Coil Spring Cover	1
C11	Start Plate	1
C12	Easy Start Coil Spring	1
C13	Easy Start Coil Spring Cover	1
C14	Flat Washer Φ 5	1
C15	Tapping Screw St4.8x13	1
C16	Tapping Screw St4.8x16	3
D	Air Intake System	1
D1	Tapping Screw St4.8x12	1
D2	Rubber Seal	1
D3	Air Filter Assembly	1
D4	Air Filter Knob	1
D5	Screw M5x50	2
D6	Air Intake Socket	1
D7	Carburetor	1
D8	Throttle Rod	1
D9	Carburetor Seat	1
D10	Suction Tube 3x6.5x110	1
D11	Circlip	1
D12	Tapping Screw St4.8x12	2
D13	Screw M5x20	2
D14	Retaining Coil	1
D15	Plate	1
D16	Air Intake Tube	1
D17	Retaining Coil	1
D18	Drivepipe Φ 7x90	1
E	Cutting System	1
E1	Chain Guide Bar	1
E2	Saw Chain	1
E3	Guide Bar Sheath	1

Assembly Diagram

SAFETY

SETUP

OPERATION

MAINTENANCE

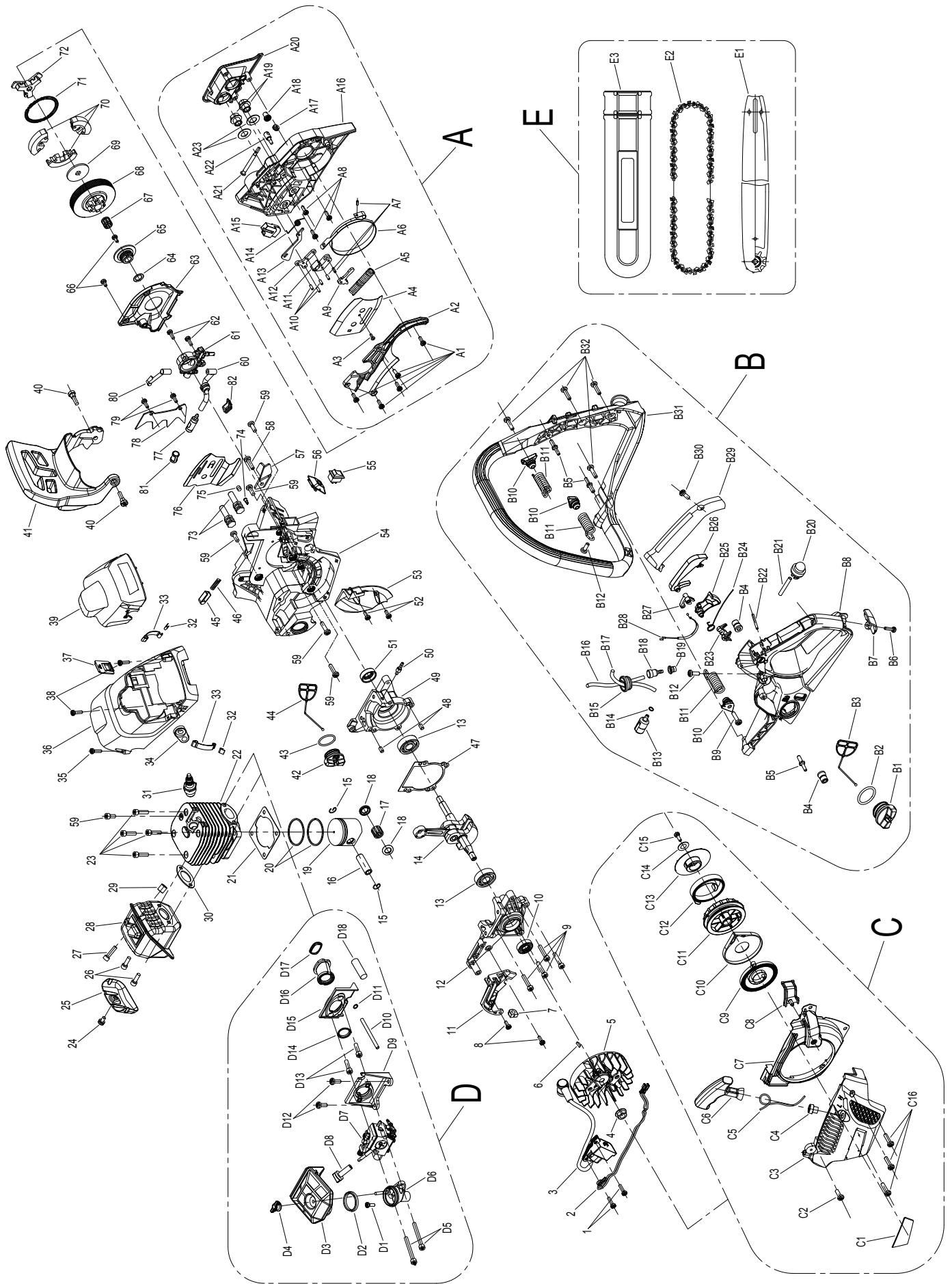

PLEASE READ THE FOLLOWING CAREFULLY

THE MANUFACTURER AND/OR DISTRIBUTOR HAS PROVIDED THE PARTS LIST AND ASSEMBLY DIAGRAM IN THIS MANUAL AS A REFERENCE TOOL ONLY. NEITHER THE MANUFACTURER OR DISTRIBUTOR MAKES ANY REPRESENTATION OR WARRANTY OF ANY KIND TO THE BUYER THAT HE OR SHE IS QUALIFIED TO MAKE ANY REPAIRS TO THE PRODUCT, OR THAT HE OR SHE IS QUALIFIED TO REPLACE ANY PARTS OF THE PRODUCT. IN FACT, THE MANUFACTURER AND/OR DISTRIBUTOR EXPRESSLY STATES THAT ALL REPAIRS AND PARTS REPLACEMENTS SHOULD BE UNDERTAKEN BY CERTIFIED AND LICENSED TECHNICIANS, AND NOT BY THE BUYER. THE BUYER ASSUMES ALL RISK AND LIABILITY ARISING OUT OF HIS OR HER REPAIRS TO THE ORIGINAL PRODUCT OR REPLACEMENT PARTS THERETO, OR ARISING OUT OF HIS OR HER INSTALLATION OF REPLACEMENT PARTS THERETO.

SAFETY

SETUP

OPERATION

MAINTENANCE

Record Product's Serial Number Here: _____

Note: If product has no serial number, record month and year of purchase instead.

Note: Some parts are listed and shown for illustration purposes only, and are not available individually as replacement parts. Specify UPC 792363574365 when ordering parts.

Limited 90 Day Warranty (Retail)

SAFETY

Harbor Freight Tools Co. makes every effort to assure that its products meet high quality and durability standards, and warrants to the original purchaser that this product is free from defects in materials and workmanship for the period of 90 days from the date of purchase. This warranty does not apply to damage due directly or indirectly, to misuse, abuse, negligence or accidents, repairs or alterations outside our facilities, criminal activity, improper installation, normal wear and tear, or to lack of maintenance. We shall in no event be liable for death, injuries to persons or property, or for incidental, contingent, special or consequential damages arising from the use of our product. Some states do not allow the exclusion or limitation of incidental or consequential damages, so the above limitation of exclusion may not apply to you. THIS WARRANTY IS EXPRESSLY IN LIEU OF ALL OTHER WARRANTIES, EXPRESS OR IMPLIED, INCLUDING THE WARRANTIES OF MERCHANTABILITY AND FITNESS, EXCEPT FOR THE EMISSIONS CONTROL SYSTEM WARRANTY BELOW.

SETUP

To take advantage of this warranty, the product or part must be returned to us with transportation charges prepaid. Proof of purchase date and an explanation of the complaint must accompany the merchandise. If our inspection verifies the defect, we will either repair or replace the product at our election or we may elect to refund the purchase price if we cannot readily and quickly provide you with a replacement. We will return repaired products at our expense, but if we determine there is no defect, or that the defect resulted from causes not within the scope of our warranty, then you must bear the cost of returning the product.

This warranty gives you specific legal rights and you may also have other rights which vary from state to state.

OPERATION

MAINTENANCE

Emissions Control System Warranty

Harbor Freight Tools (HFT) is pleased to explain the emissions control system warranty on your Small Off-Road Engine produced after January 1, [Model Year] (engine), in addition to the Retail Warranty above. HFT warrants that the emissions control system on your engine is designed, built, and equipped so that it conforms to the United States Environmental Protection Agency's (EPA) emissions requirements in effect at the time of manufacture. HFT also warrants that the emissions control system on your engine will be free from defects in material and workmanship for two (2) years, provided there has been no improper maintenance, misuse, or abuse of your engine.

Your emissions control system may include parts such as the carburetor or fuel-injection system, and the ignition system. Also included may be hoses, belts, connectors and other emissions-related assemblies.

WHAT WE WILL DO

Where a warrantable condition exists, HFT will repair or replace, at our option, any emissions-related part on your engine if it becomes defective, malfunctions, or otherwise fails to conform with this warranty under normal use and service during the two (2) year term of this warranty at no cost to you, including diagnosis, parts and labor. This warranty applies to the original purchaser and any subsequent owner within the two year warranty period.

WHAT IS COVERED?

The following parts are examples of components of the emissions control system and are covered by this two (2) year warranty. For a full list of emissions control components covered by this warranty, please see 40 CFR §1068, Appendix I.

1. Fuel Metering System
 - a. Carburetor and its internal parts.
 - b. Fuel pump (if so equipped).
 - c. Cold start enrichment system.
2. Air Induction System
 - a. Intake pipe/manifold.
 - b. Air cleaner.
3. Ignition System
 - a. Spark plug.
 - b. Magneto ignition system.
4. Catalyst System (if so equipped)
 - a. Exhaust pipe stud.
 - b. Muffler.
 - c. Catalytic converter (if so equipped).
5. Miscellaneous Items Used in Above Systems
 - a. Vacuum, temperature and time sensitive valves and switches.
 - b. Hoses, belts, connectors, and assemblies.

This warranty does not cover normal maintenance services or replacement of maintenance items such as filters, oils, or spark plugs.

WHAT YOU MUST DO TO OBTAIN WARRANTY SERVICE

As the engine owner, you are responsible for the performance of the required maintenance listed in your Owner's Manual. HFT may deny you warranty coverage if your engine or a part has failed due to abuse (including failure to follow the fuel use instructions contained in this manual), neglect, improper maintenance, or unapproved modifications.

In order to obtain warranty repair or replacement, you may either (a) contact HFT product support at 1-888-866-5797 or productsupport@harborfreight.com; or (b) bring the to your nearest Harbor Freight Tools retail store. When going to the retail store or contacting product support, you must indicate the specific emissions control part or defect that you are claiming and the date this was originally purchased. The nearest Harbor Freight Tools retail store can be found on the internet at <http://www.harborfreight.com>.

PORTLAND™

26677 Agoura Road • Calabasas, CA 91302 • 1-888-866-5797